

# IHTC-16 Fourier Lecture

## HISTORICAL DEVELOPMENT IN THE THOUGHT OF THERMAL SCIENCE—HEAT AND ENTROPY

PREFACE AND CHAPTERS 18–20  
(250 YEARS AFTER JAMES WATT AND  
200 YEARS AFTER SADI CARNOT)

Yoshitaka Yamamoto  
**Surugadai Gakuen, Tokyo, Japan**

**English Translation & Presentation**  
Hideo Yoshida  
**Kyoto University, Kyoto, Japan**

# Yoshitaka Yamamoto (1941–)

Historian of Science, Natural Philosopher, Educator

1964: BS, Department of Physics, **The Univ. of Tokyo**  
also studied at Yukawa  Inst. for Theoretical Physics, **Kyoto Univ.**

1968–9: Representative of **The Univ. of Tokyo**  
All-Campus Joint Struggle League 

1976– : Sundai (Surugadai) Preparatory School

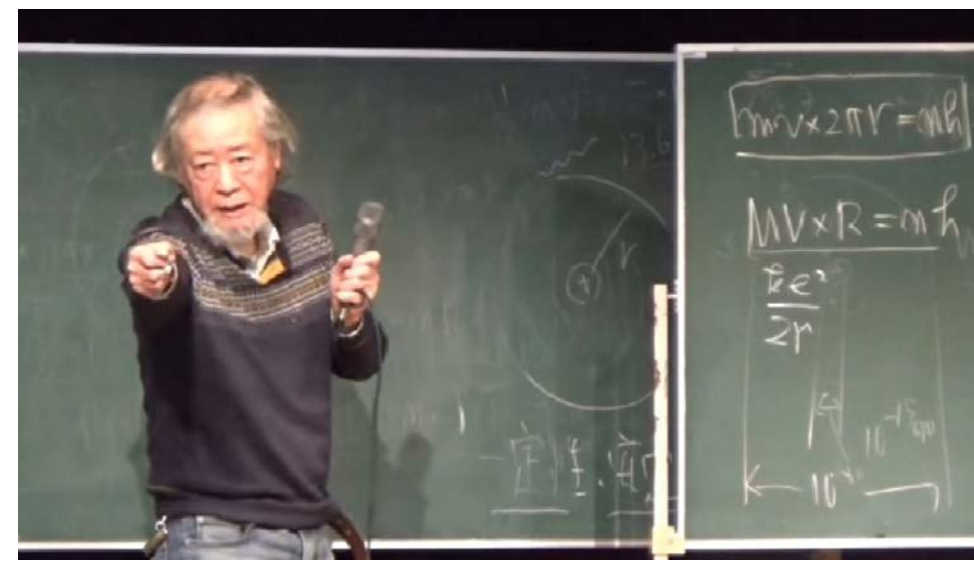

## Original Works

- Gravity and Mechanical World (1981)
- Formation of Classical Mechanics: From Newton to Lagrange (1997)
- Analytical Mechanics (1998)
- The Pull of History—Human Understanding of Magnetism and Gravity through the Ages, 1-3 (2003 in Japanese, 2018 in English)
- Cultural Revolution in the 16th Century, 1-2 (2007)
- On Fukushima Nuclear Accident: What I learned and considered (2011)
- Conversion of World View, 1-3 (2014)
- Canonical Theory of Geometrical Optics (2014)
- Atom, Nucleus and Nuclear power: What I wanted to tell young students (2015)
- 150 Years of Modern Japan: Bankruptcy of All-out War Based on Science and Technology (2018)
- Discovery of Decimal and Logarithm (2018)

## Ernst Cassirer (Japanese translation)

- Zur Einsteinschen Relativitätstheorie. Erkenntnistheoretische Betrachtungen (1976)
- Substanzbegriff und Funktionsbegriff. Untersuchungen über die Grundfragen der Erkenntniskritik (1979)
- Das Erkenntnisproblem in der Philosophie und Wissenschaft der neueren Zeit 4 (1996)

## Niels Bohr (Japanese translation)

- Niels Bohr Collected Works, 1-2 (1999, 2000)

# The Pull of History—Human Understanding of Magnetism and Gravity through the Ages

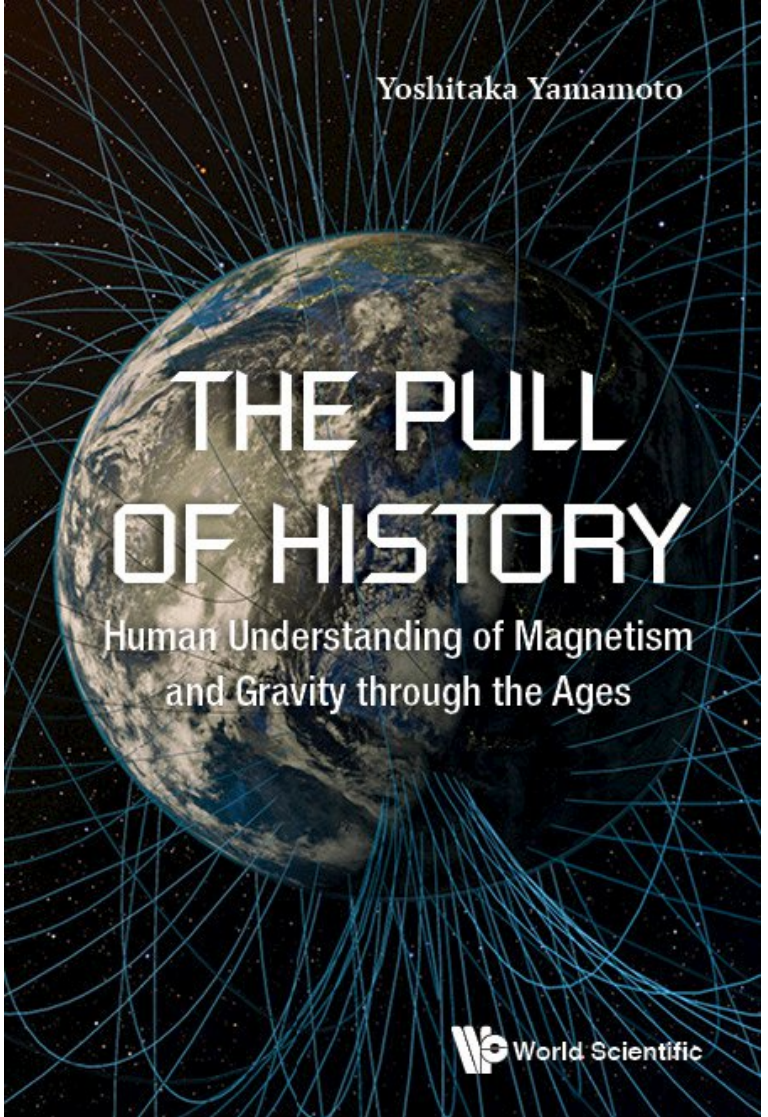

**Original in Japanese (2003)  
English translation (2018)**

- **Part 1. Antiquity and the Middle Ages  
Chapters 1–8**
  
- **Part 2. Renaissance  
Chapters 9–16**
  
- **Part 3. The Dawn of the Modern Age  
Chapters 17–22**

<https://www.worldscientific.com/worldscibooks/10.1142/10540>



# Historical Development in the Thought of Thermal Science —Heat and Entropy (1986, 2009)

## Preface

Part 1 Materialism and Dynamical Reductionism  
Chapter 1–6

Part 2 Formation of Caloric Theory  
Chapter 7–12

Part 3 Calorimetry and Conservation of Heat  
Chapter 13–17

Part 4 Motive Power of Heat—Carnot and Joule  
**Chapter 18–20–24**

Part 5 Proposal of the Principles of Thermodynamics  
Chapter 25–29

Part 6 Energy and Entropy  
Chapter 30–34

Postscript



3 volumes,  
more than  
1000 pages

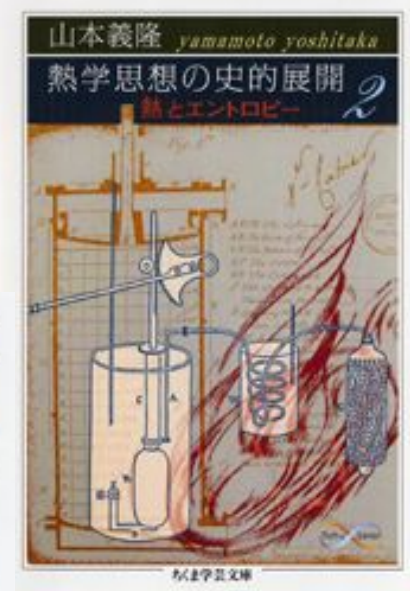

# from Galilei to Nernst

1550 1600 1700 1800 1900 1950

- Galileo Galilei (1564–1642)
- Pierre Gassendi (1592–1655)
- René Descartes (1596–1650)
- Robert Boyle (1627–1691)
- Robert Hooke (1635–1703)
- Isaac Newton (1642–1727)
- Thomas Savery (ca.1650–1715)
- Thomas Newcomen (1664–1729)
- Herman Boerhaave (1668–1738)
- Stephen Hales (1677–1761)
- John Theophilus Desaguliers (1683–1744)
- Colin Maclaurin (1698–1746)
- Benjamin Franklin (1706–1790)
- William Cullen (1710–1790)
- David Hume (1711–1776)
- Joseph Black (1728–1799)
- James Watt (1736–1819)
- William Irvine (1743–1787)
- Antoine Laurent Lavoisier (1743–1794)
- Pierre-Simon Laplace (1749–1827)
- Benjamin Thompson, Count Rumford (1753–1814)
- Lazare Carnot (1753–1823)
- William Cleghorn (1754–1783)
- John Dalton (1766–1844)
- Jean-Baptiste Joseph Fourier (1768–1830)
- Thomas Young (1773–1829)
- Charles Bernard Desormes (1777–1838)
- Louis Joseph Gay-Lussac (1778–1850)
- Nicolas Clément (1779–1841)
- Siméon Denis Poisson (1781–1840)
- Michael Faraday (1791–1867)
- William Whewell (1794–1866)
- Nicolas Léonard Sadi Carnot (1796–1832)
- Emile Clapeyron (1799–1864)
- Henri Regnault (1810–1878)
- Carl Holtzmann (1811–1865)
- Julius Robert von Mayer (1814–1878)
- James Prescott Joule (1818–1889)
- Hermann Ludwig Ferdinand von Helmholtz (1821–1894)
- Rudolf Julius Emanuel Clausius (1822–1888)
- William Thomson, 1st Baron Kelvin (1824–1907)
- Julius Thomsen (1826–1909)
- Pierre Eugène Marcellin Berthelot (1827–1907)
- James Clerk Maxwell (1831–1879)
- Josiah Willard Gibbs (1839–1903)
- August Horstmann (1842–1929)
- Ludwig Eduard Boltzmann (1844–1906)
- Jacobus Henricus van't Hoff (1852–1911)
- Max Karl Ernst Ludwig Planck (1858–1947)
- Walther Hermann Nernst (1864–1941)

**James Watt**  
1736–1819

**Separate condenser**  
1769: 249 years ago

**“250 Years after James Watt and  
200 Years after Sadi Carnot”**

**Sadi Carnot**  
1796–1832

**Carnot’s theorem**  
1824: 194 years ago

1600 1700 1800

# Contents of Original Book

## Chap. 18 Setting of a New Problem —“Motive Power” of Heat —Carnot and Watt

- I. Neglect of Carnot’s paper during his lifetime
- II. Carnot’s premise and problem setting
- III. Caloric theory and cosmology based on heat
- IV. Carnot’s view of nature and of society based on heat
- V. Develop. of steam engine and its defects before **Watt**
- VI. **Watt**’s improvement—separate condenser
- VII. **Watt**’s improvement—expansive principle
- VIII.  $P$ – $V$  diagram and expression for work (**Watt**)
- IX. High-pressure engine and its development in France

## Chap. 19 Theory of Ideal Heat Engine —Carnot's Theorem

- I. Purpose of Carnot's paper
- II. Carnot's preliminary theorem and its background  
(the first and second premises)
- III. Carnot cycle
- IV. Carnot's theorem (the third premise)

## Chap. 20 Structure of Carnot's Theory and its Extension —The Start of Thermodynamics

- I. Premises of Carnot's theory (premises A, B, and C)
- II. Analytical expression for Carnot's theorem (expressions I and II)
- III. Experimental determination of Carnot function
- IV. Extension of Carnot's theory and gas theorem (gas theorems 1, 2, and 3)
- V. Further discussion and significance of thermodynamics



# Contents of This Lecture

45

1. **Development of Steam Engine in England and its Impact on France** ..... 44
2. **Sadi Carnot and Neglect of his Paper during his Lifetime** ..... 33
3. **Carnot's Theorem** ..... 22
4. **Structure of Carnot's Theory and its Extension.....** 8

# 1. Development of Steam Engine in England and its Impact on France



**Matthew Boulton**

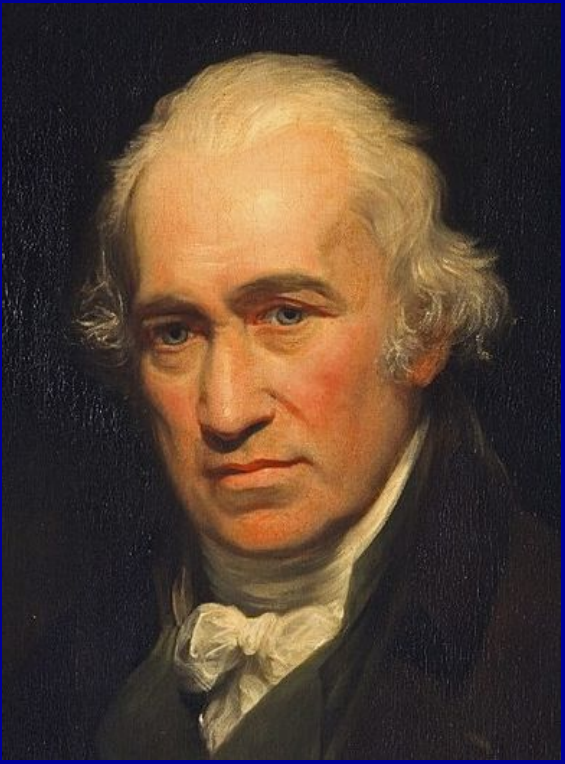
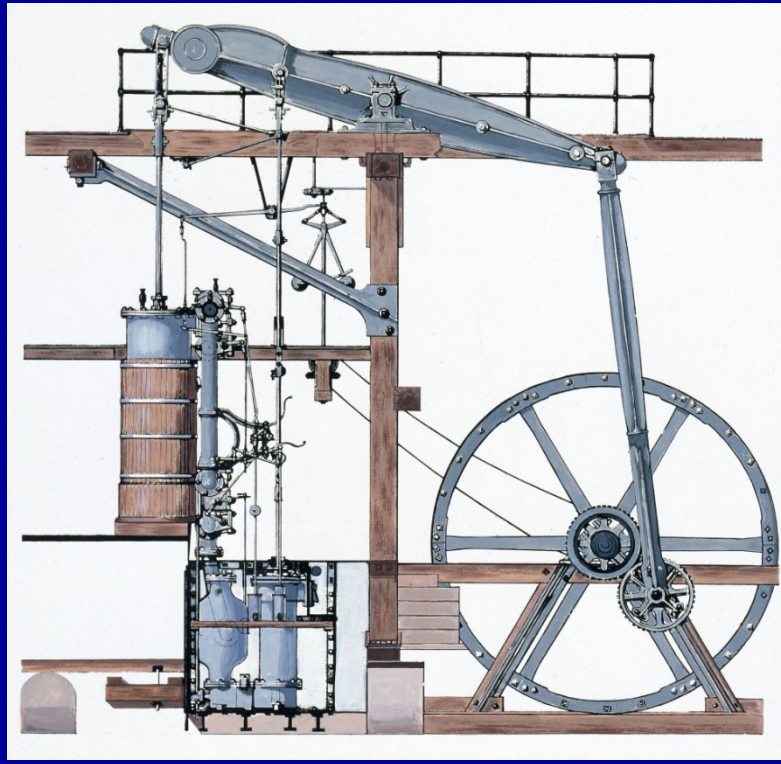

**James Watt**

# Effective means of removing and lifting spring water from mines 16–17th century

- Increased demand for metals owing to the modernization of weapons
- Development of a money economy

Many lifting pumps in “*De re Metallica*”

by Agricola (**German**)

“*The Various and Ingenious Machines*”

by Ramelli (**Italy**)

Also, in **England**

*“the fifty-five patents for inventions granted during the reign of Elizabeth, 1561-99, one in seven is for the raising of water”* [Dickinson, 1938]

Denis Papin (1647–1713) (**France**)  
Piston steam engine (1690)

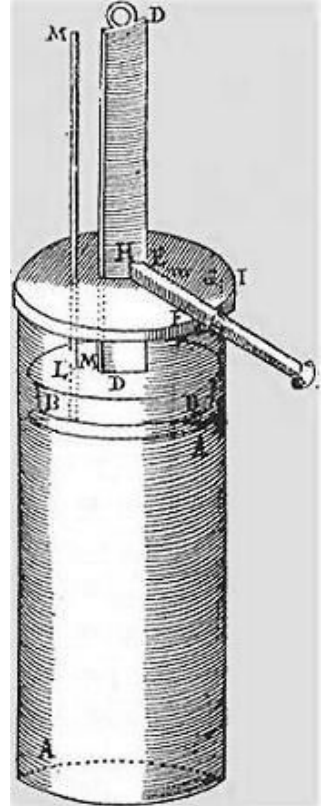

A cylinder filled with water was heated, and a piston lifted by steam was then cooled by water.



# Thomas Savery (ca.1650–1715)

- In **England**, water drainage was particular critical problem
- Thomas Savery (later, & Thomas Newcomen) in the southwest of England developed an actual water-pumping machine by using steam

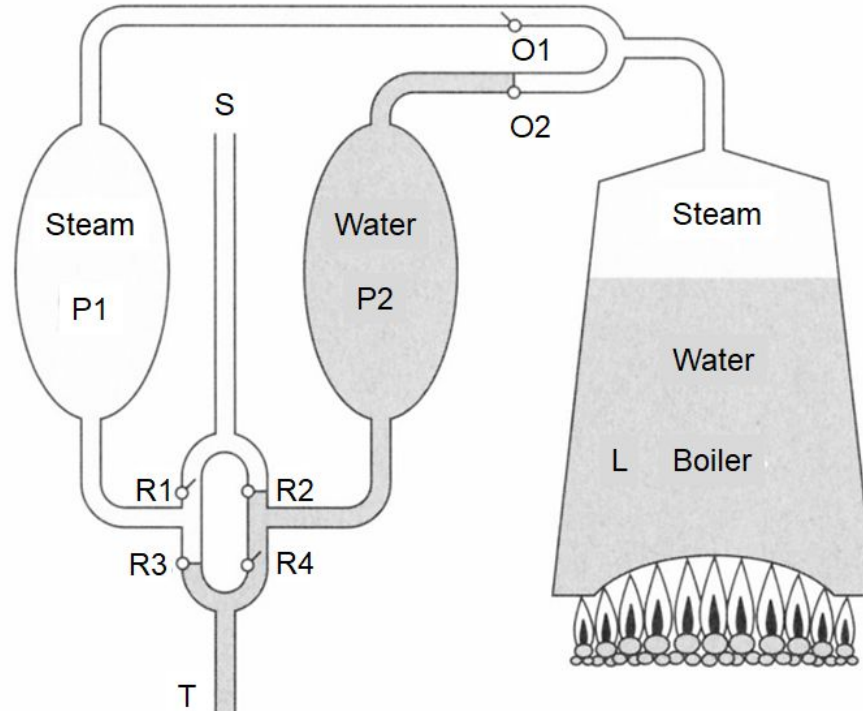
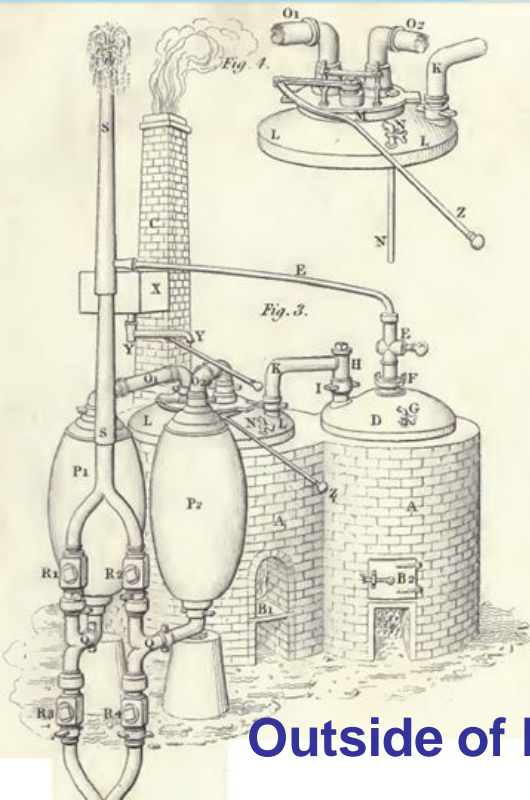

Outside of P1/P2 is cooled by water

## Defects

- not work in principle more than 10m column of water,
- practical limitations owing to the immature high-pressure technology
- the low efficiency associated with cooling from the outside of the container
- could not practically contribute

# Thomas Newcomen (1664–1729)

- On the basis of **Papin**'s idea, Thomas Newcomen separated the cylinder and boiler.
- Newcomen's practically useful engine (around 1712) have revitalized the coal mines in England



*“There is **no known image** of Thomas Newcomen”*  
<http://www.newcomen.com/about-the-society/thomas-newcomen/>





# Newcomen's steam engine & Smeaton's improvement

40

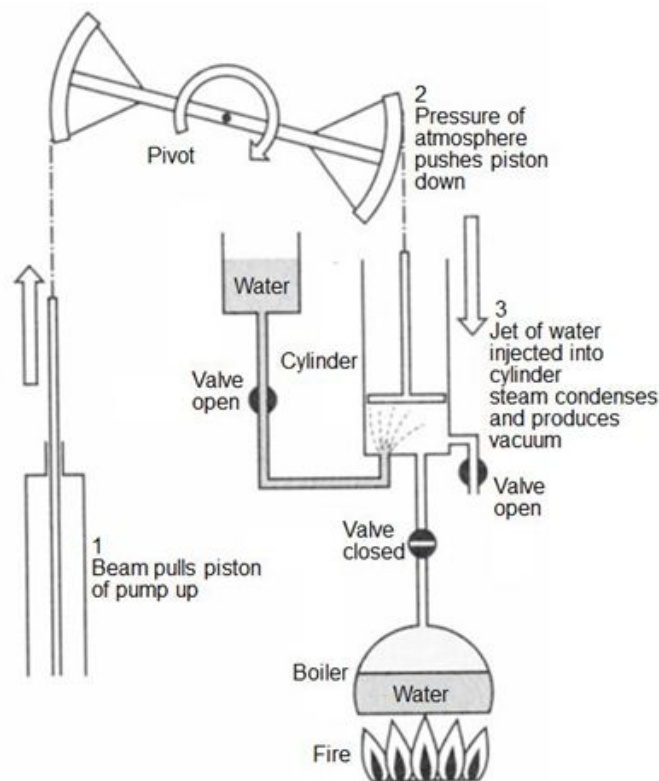
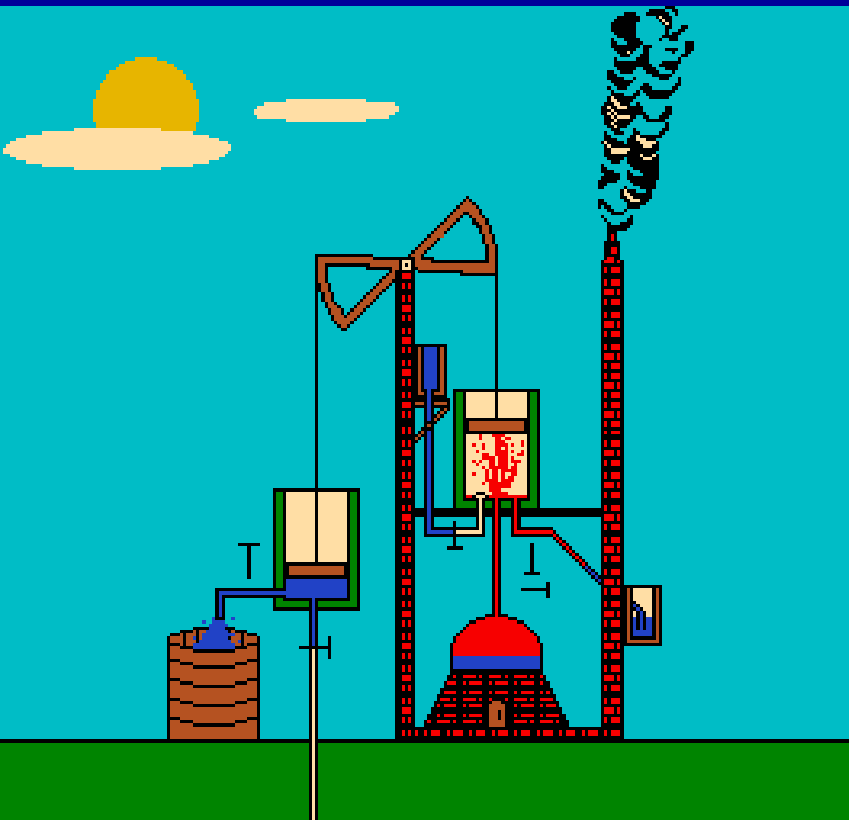

John Smeaton  
(1724–1792)

“father of civil engineering”

- When the cylinder is full of steam, **cold water is sprayed** into it so that a vacuum is formed.
- At that time, it was understood that the **vacuum** inside the cylinder jacks up the piston, rather than that **atmospheric pressure** pushes down the piston.

- also, tried to improve its efficiency
- but, no essential improvements until those by **Watt** a half-century later.

# James Watt—Philosophical instrumentmaker to the University of Glasgow since 1757

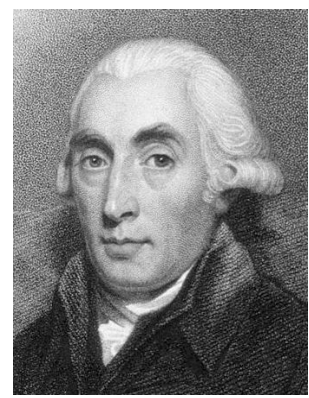

Joseph Black (1728–1799)

- Analytical balance
- Latent heat
- Specific heat



John Robison (1739–1805)

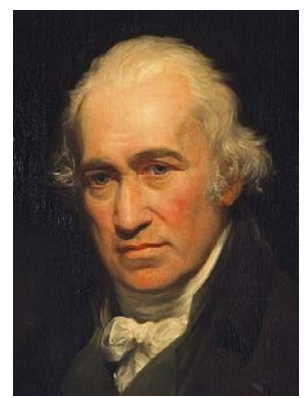
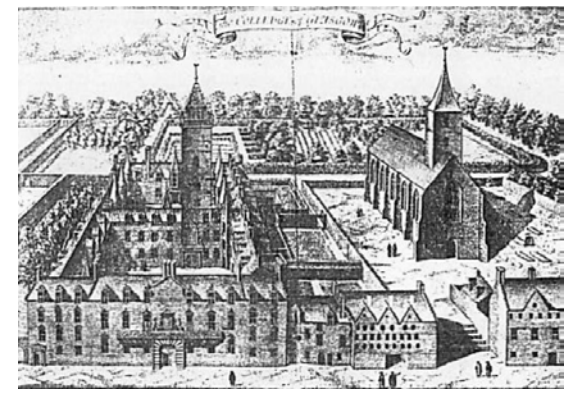

James Watt (1736–1819)

- The fact that in the university **scientists** and a **craftsman** could have discussions and cooperate was due to not only the intellectual atmosphere in Glasgow but also Watt’s own temperament.
- Watt (1809) *“Every thing I learnt from him (=Black) was in conversation and by doing small mechanical jobs for him. These Conversations and those I had with you (=Robison) served to give me true notions in Science.”*
- Robison (1758) *“I saw a workman and expected no more: I found a philosopher.”*

# Watt encountered Newcomen's engine by chance

*“in the Winter of 1763, having occasion to repair a Model of Newcomen's Engine which belonged to the Natural Philosophy class of the University of Glasgow;”*

*“I found that the Boiler, though large in proportion to the Cylinder could not supply it with Steam to work at a proper rate unless the fire was violently urged with bellows.”*

**A** the net amount of steam required for the operation

**V** the volume of the cylinder

**$\Delta A$**  an amount of steam

**S** the inner surface area of the cylinder

$$\frac{\Delta A}{A} \propto \frac{aS}{V} \propto \frac{a}{l}$$

**l** the characteristic length of the model

**a** is a constant with the dimension of length

→ the ratio increases with decreasing size of the model

By observing the miniature steam engine model, the essential defect of Newcomen's engine was brought to the fore.

# Separate condenser (1769: 249 years ago)

- To reduce fuel consumption: the cylinder at a high temperature
- for high mechanical performance: effective cooling

**Watt found a method to simultaneously satisfy both requirements by spatially and substantially separating the expansion process and contraction process.**

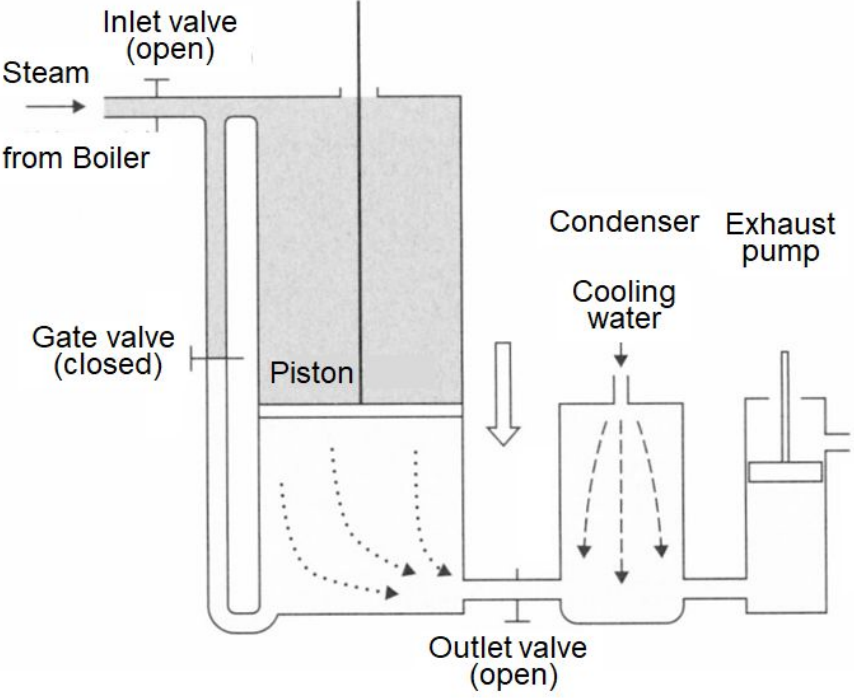
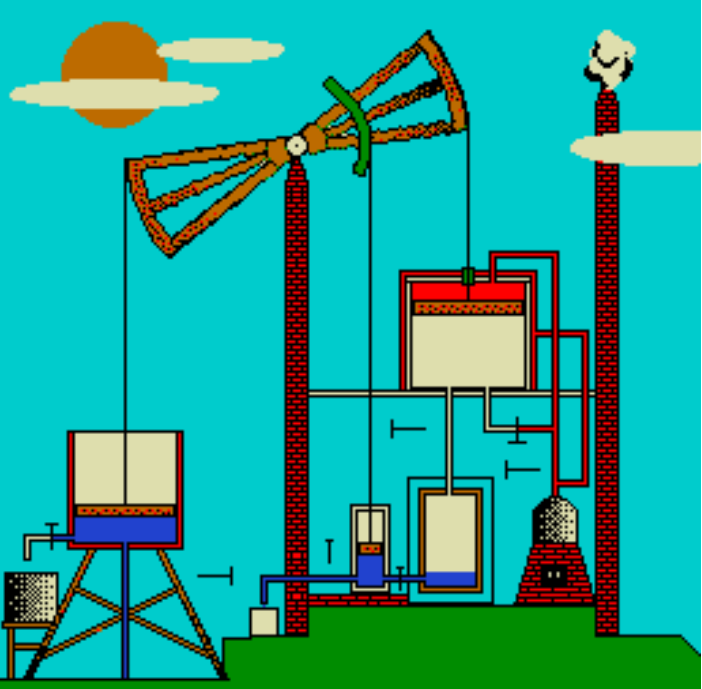

Although this is very simple from the present perspective, it was *“the greatest single improvement ever made in the engine.”* [Dickinson, 1938]



# Boulton & Watt

## Royalty: 1/3 of fuel saved



Business partner  
Matthew Boulton  
(1728–1809)

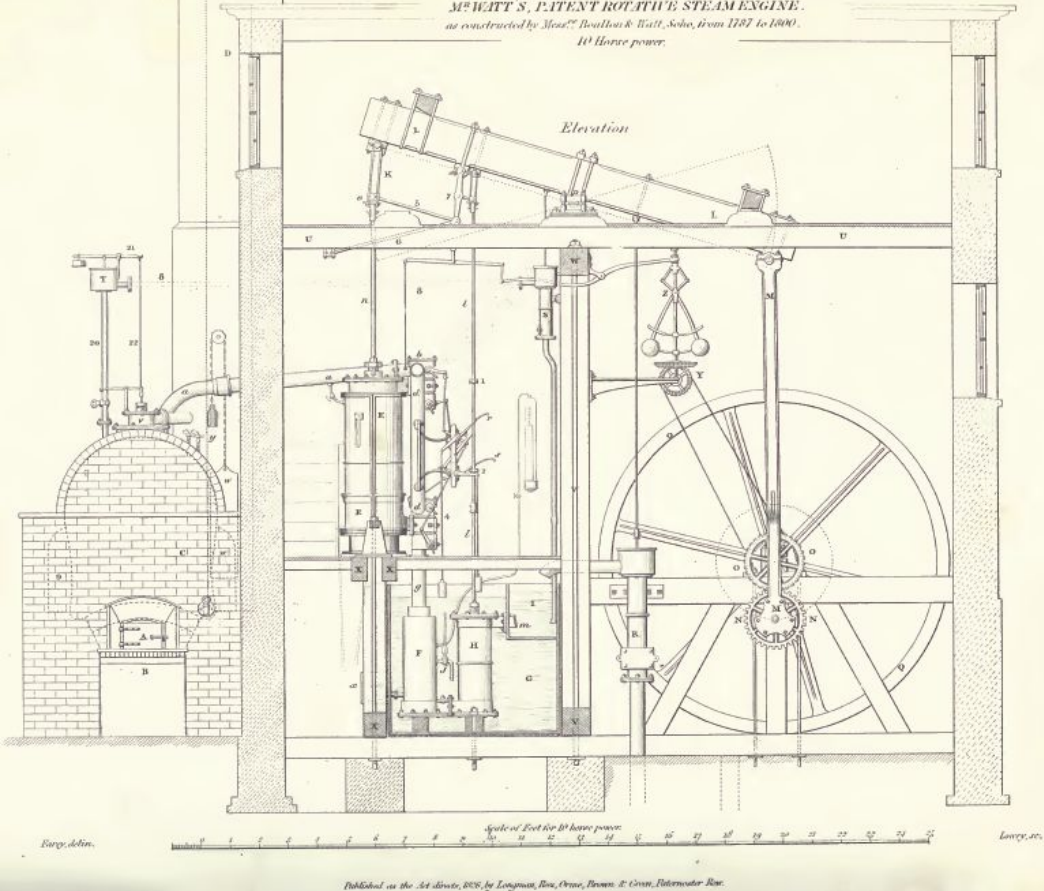

- In 1782, Watt invented a double acting engine, operated by steam in both the upward and downward directions. A 100% steam engine, whose operation was **independent of atmospheric pressure and gravity**, had been developed.

■ *“Watt & Boulton decided that their engine should be paid for by a royalty, or as they termed it a ‘premium’, based very appropriately on the saving in fuel effected by the engine as compared with the consumption of a common engine (Newcomen) doing the same work. Boulton & Watt stipulated that they should receive one-third of the value of the fuel saved.”* [Dickinson, 1938]



# Advance in steam engine

- 1800 Expiration of Watt's patent
- 1802 **Trevithick**: High-press. engine
- 1807 **Fulton**: Steamboat

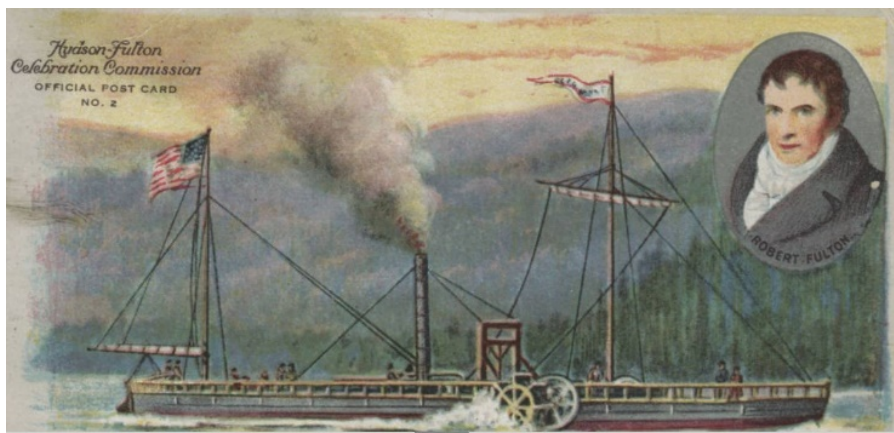
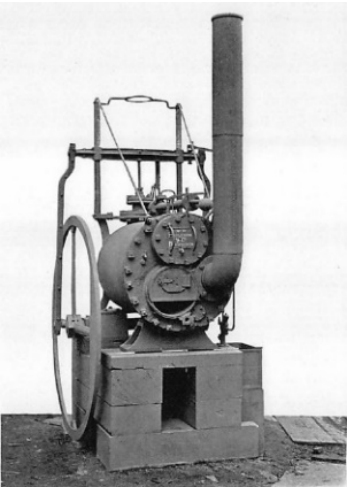

- 1814 **Carnot**: graduated from École Poly.
- 1815 Napoleonic Wars ended

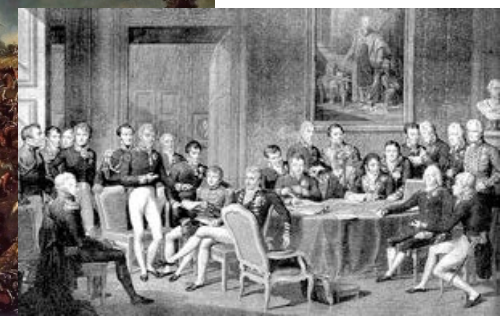

## 1814 **Woolf**: Compound engine

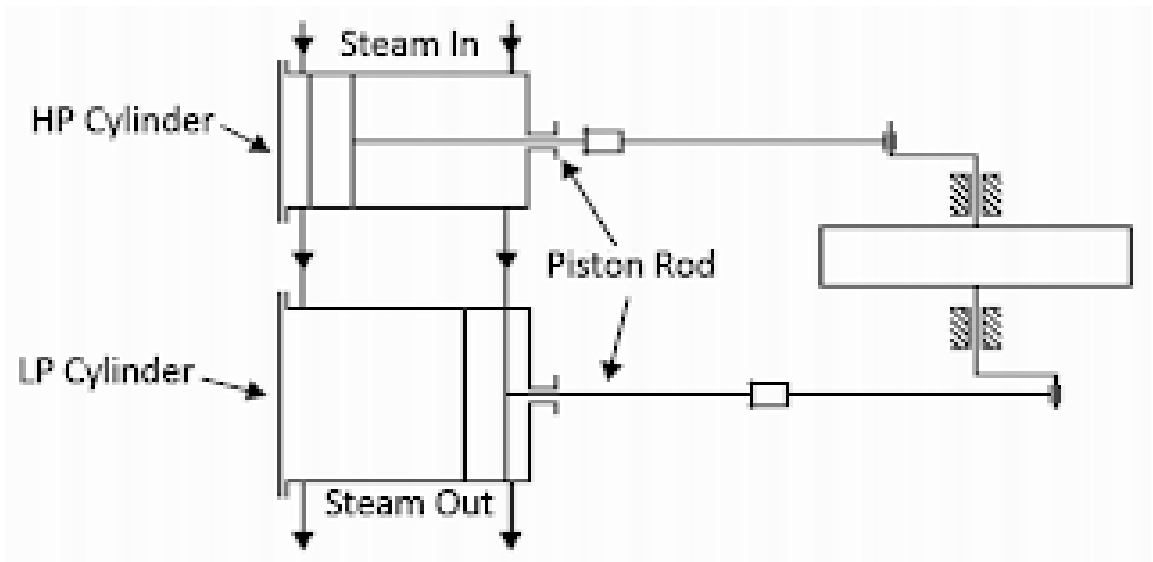

*“From the very start the Woolf compound engine ... which made use of high pressure to operate two cylinders alternately and offered a fuel economy over the Watt engine of about 50 per cent found its greatest market in France.”*  
 [Landes, 1965]

# Railway & its impact on France (1820–30s)

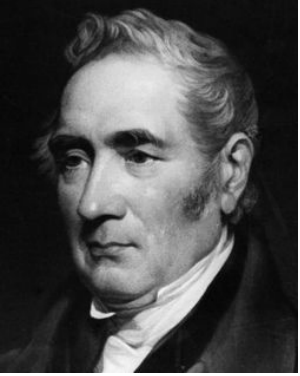

**George Stephenson**  
(1781–1848)

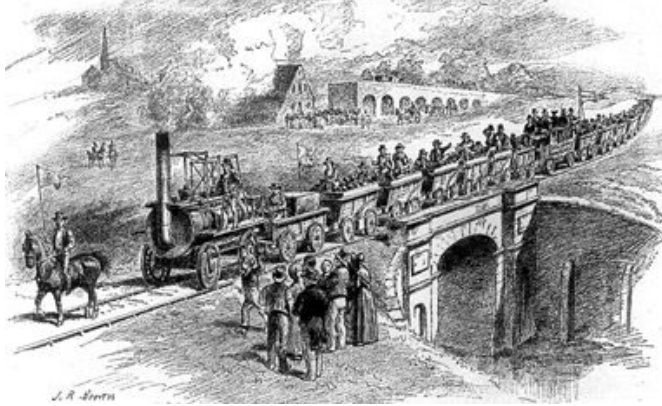

**1825 Stockton-Darlington**

*“By them, he turns each drop of water into a reservoir of steam, .....Is there any thing which gives a higher idea of the power of man, than the steam-engine under the form in which it is applied to produce motion on railroads?”*  
(1836)



**Saint-Simonianism**  
**Michel Chevalier**  
(1806–79)



**Marc Seguin**  
(1786–1875)

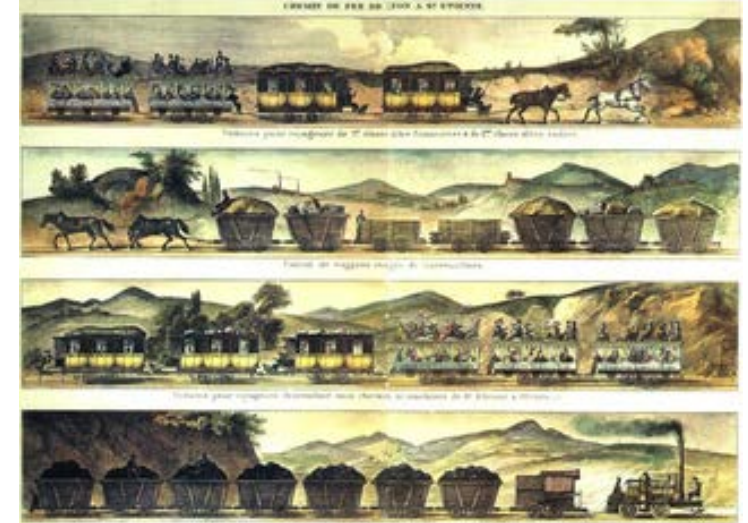

*“ just there a drop of water turned into steam acts to supplement his weakness, to create for him a power of which we cannot now, nor yet for a long time to come, measure the extent. From now on with the help of this agent ..... ”* (1839)

In western Europe, which rushed headlong toward a highly industrialized society, the predominance of human beings over nature was first recognized; this presumptuous philosophy was based on the development of **steam engines**.



# 2. Sadi Carnot and Neglect of his Paper during his Lifetime

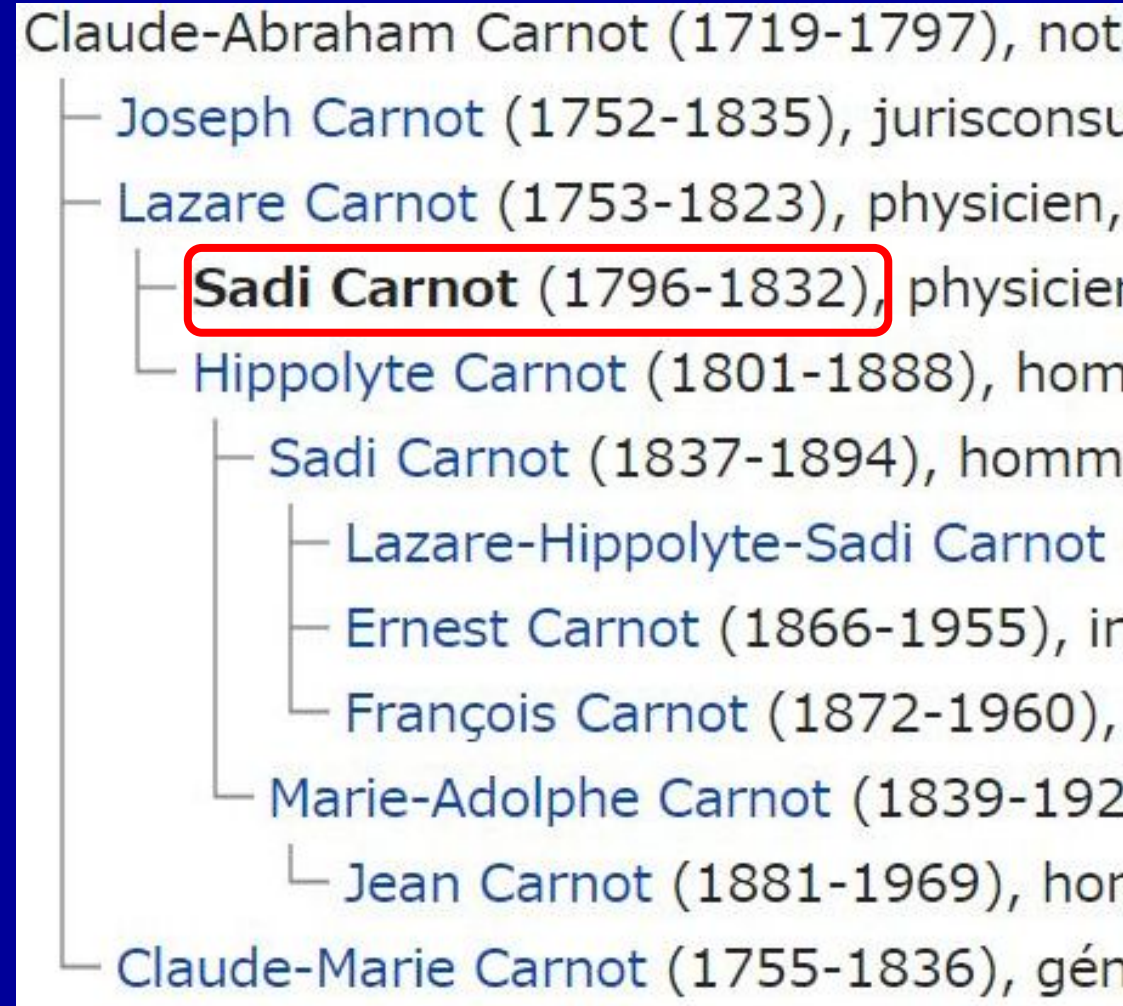
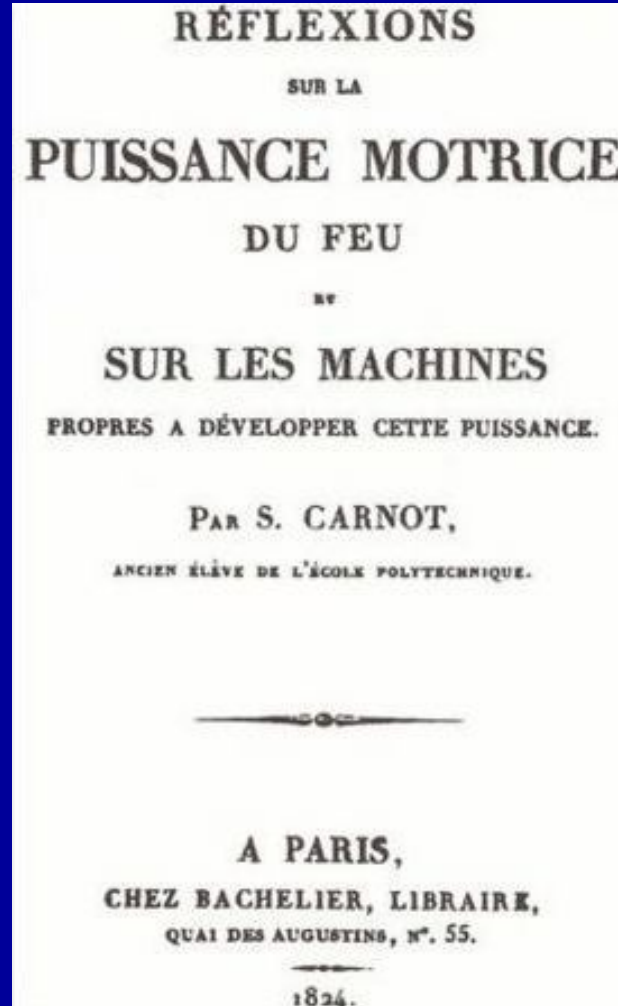

# In 1832, Galois & Carnot—The light of science from Paris

32

France experienced successive early deaths of two great geniuses in mathematics and physics



**Évariste Galois**

(October 25, 1811–**May 31, 1832**)

**20 years old**, killed by duel



**Nicolas Léonard Sadi Carnot**

(June 1, 1796–**August 24, 1832**)

**36 years old**, died of cholera

The driving force of their work was the French intellectual atmosphere of that age, as if

*“the whole of Europe was illuminated by the light of science which emanated from Paris during the first third of this century.”* [Merz, 1904]

# Carnot Family

[https://fr.wikipedia.org/wiki/Sadi\\_Carnot\\_\(physicien\)](https://fr.wikipedia.org/wiki/Sadi_Carnot_(physicien))

Claude-Abraham Carnot (1719-1797), notaire royal

— Joseph Carnot (1752-1835), jurisconsulte

— Lazare Carnot (1753-1823), physicien, mathématicien, général

— Sadi Carnot (1796-1832), physicien et ingénieur

— Hippolyte Carnot (1801-1888), homme politique

— Sadi Carnot (1837-1894), homme politique

— Lazare-Hippolyte-Sadi Carnot (1865-1948), colonel et écrivain

— Ernest Carnot (1866-1955), industriel et homme politique

— François Carnot (1872-1960), ingénieur et homme politique

— Marie-Adolphe Carnot (1839-1920), chimiste, géologue et homme politique

— Jean Carnot (1881-1969), homme politique

— Claude-Marie Carnot (1755-1836), général et homme politique

**“the Organizer of Victory”  
in the French Rev. Wars**



Lazare



Hippolyte

*“He had such a repugnance to bringing himself forward that, in his intimate conversations with a few friends, he kept them ignorant of the treasures of science which he had accumulated.” [Hippolyte]*

**Despite his reticence, however, he was a quarter of a century ahead of the physicists at that time.**



# Sadi Carnot's three manuscripts

Graduated from the École Polytechnique in Paris (1814).

- “*Réflexions sur la Puissance Motrice du Feu (Reflections on the Motive Power of Fire)*” (1824)
- “*Notes sur les Mathématiques, la Physique et autres sujets*” (belatedly 1878)
- “*a draft of the Réflexions*” (discovered in 1964)

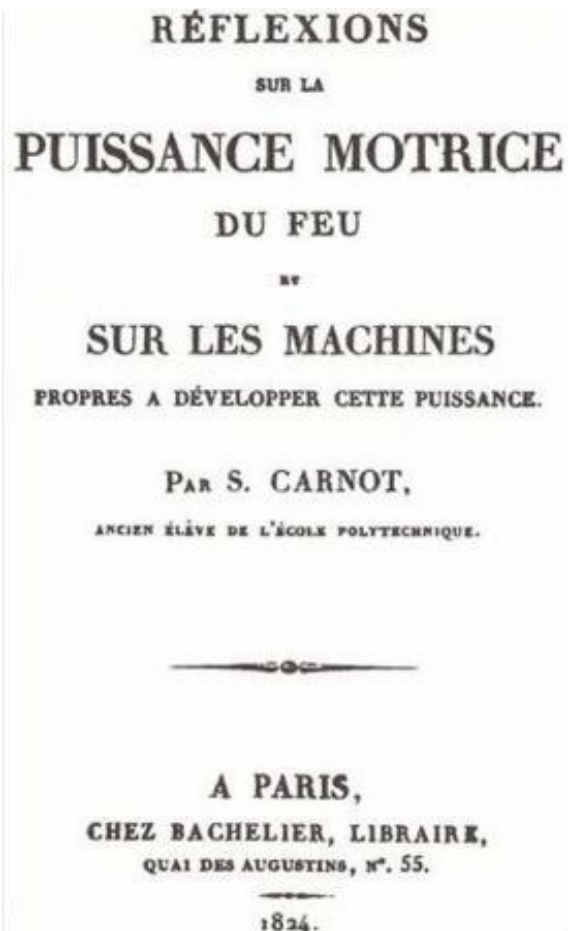

In physics, if a problem has been properly defined, its solution is generally near at hand.

In this sense, it is no exaggeration to say that

**the birth and consolidation of thermodynamics and its foundations were almost entirely due to a single paper: *the Réflexions***

- *“If you were now to deprive England of her steam engines, you would deprive her of both coal and iron; you would cut off the sources of all her wealth, totally destroy her means of prosperity, and reduce this nation of huge power to insignificance.”*
- *First, “The question whether the motive power of heat is limited or whether it is boundless has been frequently discussed. Can we set a limit to the improvement of the heat engine, a limit which, by the very nature of things, cannot in any way be surpassed? Or, conversely, is it possible for the process of improvement to go on indefinitely?”*
- *Second, “is the motive power of heat fixed in quantity, or does it vary with the working substance that is used? Does it vary with the intermediary material that we subject to the action of heat?”*

- *“The phenomenon of the production of motion by heat has not been treated from a sufficiently general point of view.”*
- *“In order to grasp in a completely general way the principle governing the production of motion by heat, it is necessary to consider the problem independently of any mechanism or any particular working substance. Arguments have to be established that apply not only to steam engines but also to any conceivable heat engine, whatever working substance is used and whatever operations this working substance is made to perform.”*
- *“but such a theory is plainly lacking in the case of the heat engine. It will only be achieved when the laws of physics are sufficiently extensive and general for us to be able to predict all the effects that are produced when heat acts in a particular way on any given substance.”*

**Possibly the most astonishing fact about Sadi Carnot's work is that it was received in complete silence by the world of French science. [Mendoza, 1959]**

*"A few days after its publication, Carnot's book was formally presented to the Académie des Sciences; It was presented by Girard, a prominent engineer. Among the Academicians present were:*

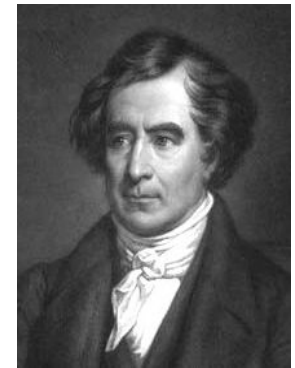

**Arago**



**Fourier**

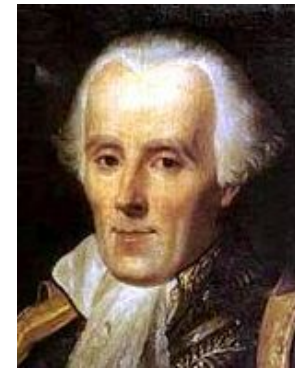

**Laplace**



**Ampère**



**Gay-Lussac**



**Poinsot**



**Fresnel**



**mistakenly used for nearly 200 years**

**Legendre**



**Poisson**



**Cauchy**



**Dulong**

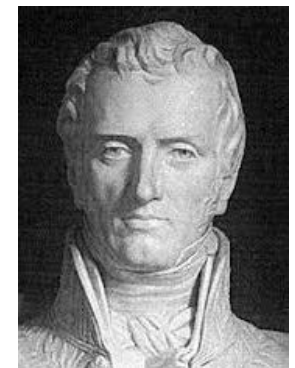

**Navier**



**Prony**

*In fact, Carnot's book made hardly a ripple on the surface of the main stream of science." [Cardwell, 1971]*



# Not principal but subsidiary reason of neglect

- Main stream  
traditionally interested in pure mathematical science—  
**D'Alembert, Laplace, and Lagrange,**

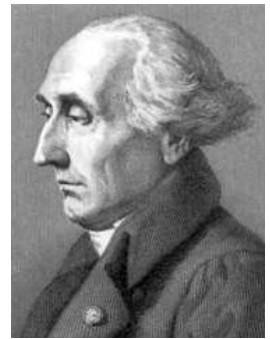
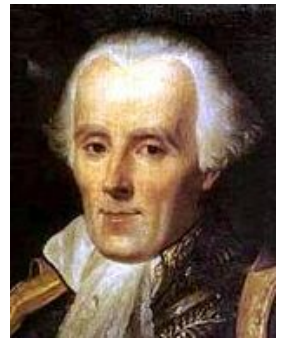

- Relatively minor stream  
based on practical engineering—**Lazare and Sadi Carnot**

Exception of non-neglect of *the Réflexions*  
a manuscript book of notes taken by a student who attend the course of lectures given by **Clément** at the Conservatoire des Arts et Métiers in 1824–25 and later years



# Principal reasons of neglect and its significance

- A major issue not only for Carnot but also for all the researchers and engineers of steam engines—**Why high-pressure engines were superior to low-pressure engines.**
- Only Carnot could **thoroughly investigate this issue from the principles**, and a single paper of Carnot provided the basis for thermodynamics.

- Carnot's work was originally stimulated by **a technical issue that was not of interest to physicists.**
- Simultaneously, its approach was **so fundamental and theoretical that it was not understood by engineers,**
- and was therefore neglected.

*“The most original study in physical science” [Larmor, 1916]*

- Note that the year of 1824 when Carnot published *the Réflexions* was one year after the completion of analytical calorimetry by Laplace and Poisson: the heyday of **caloric theory.**

# Excavation by **Émile Clapeyron** (1799–1864)



- Graduated from the École Polytechnique in Paris (1818) (3 years younger than Carnot)
- In 1834, he took up *the Réflexions* and gave it **graphical and mathematical expressions** in *Mémoire sur la Puissance Motrice de la Chaleur* (*Memoir on the Motive Power of Heat*)

- Clapeyron’s paper first expressed the Carnot cycle as an indicator diagram in the  $P-V$  plane, and also pointed out that the area enclosed by the cycle lines is equal to the work.

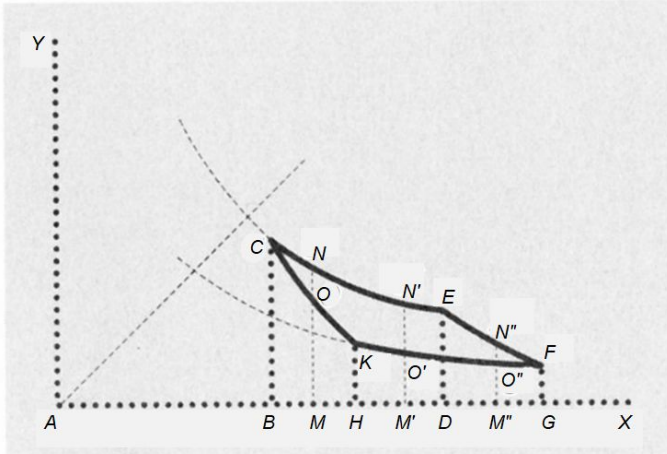

■ “S. Carnot, avoiding the use of mathematical analysis, arrives by a chain of difficult and elusive arguments at results which can be deduced easily from a more general law which I shall attempt to prove.” [Clapeyron]

***The Réflexions, however, still continued to be neglected.***

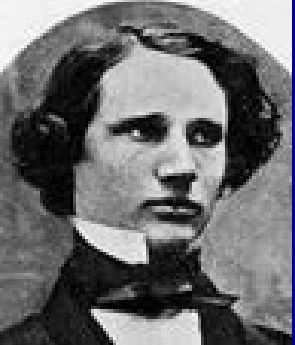

**William Thomson** (born in 1824, later, **Lord Kelvin**)

*The Réflexions* finally reached a reader with a stature comparable to its author in 1848, 24 years after its publication.

*“The perusal of this mémoire incited Thomson to refer to the original tract of Carnot. In vain did he inquire for it in the Library of the Collège de France. No one could tell him even where a copy might be seen. But a copy he must have, even if he searched all Paris to find it. ....*

*I (= Thomson) went to every book-shop I could think of, asking for the Puissance motrice du feu, by Carnot. “Caino? Je ne connais pas cet auteur.” With much difficulty I managed to explain that it was “r” not “i” I meant. “Ah! Ca-rrr-not! Oui, voici son ouvrage,” producing a volume on some social question by Hippolyte Carnot; but the Puissance motrice du feu was quite unknown.*

*..... Not until the end of the year 1848 did he (= Thomson) see the book, a copy of it being sent by Professor Lewis Gordon.”*

# 3. Carnot's Theorem

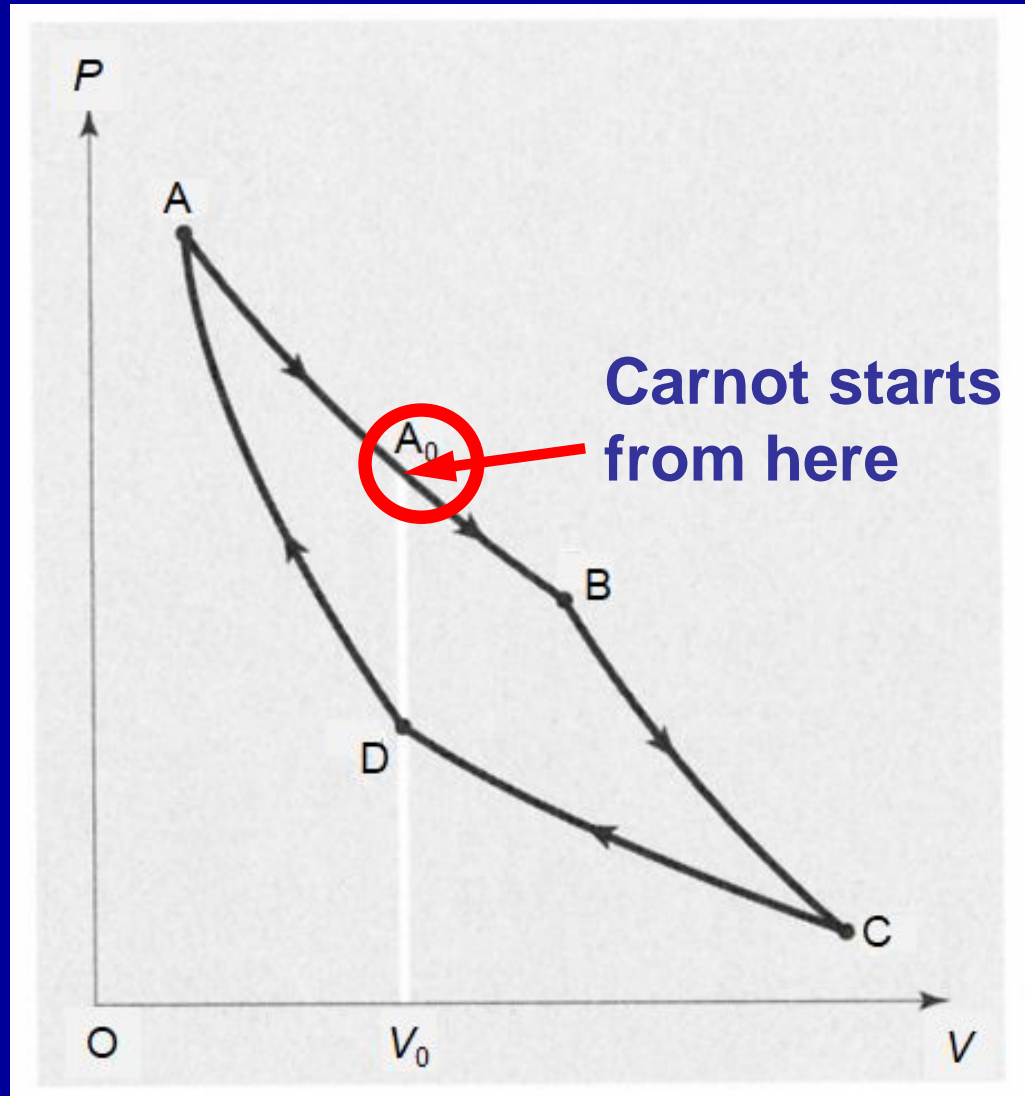



# Expansive principle—Watt & Carnot

In **Watt's** patent of 1782, one more improvement, which is very important in terms of thermodynamics, was based on

- by adiabatic expansion of the steam, the steam will be gradually cooled
- simultaneously carrying out work with the energy contained in the steam

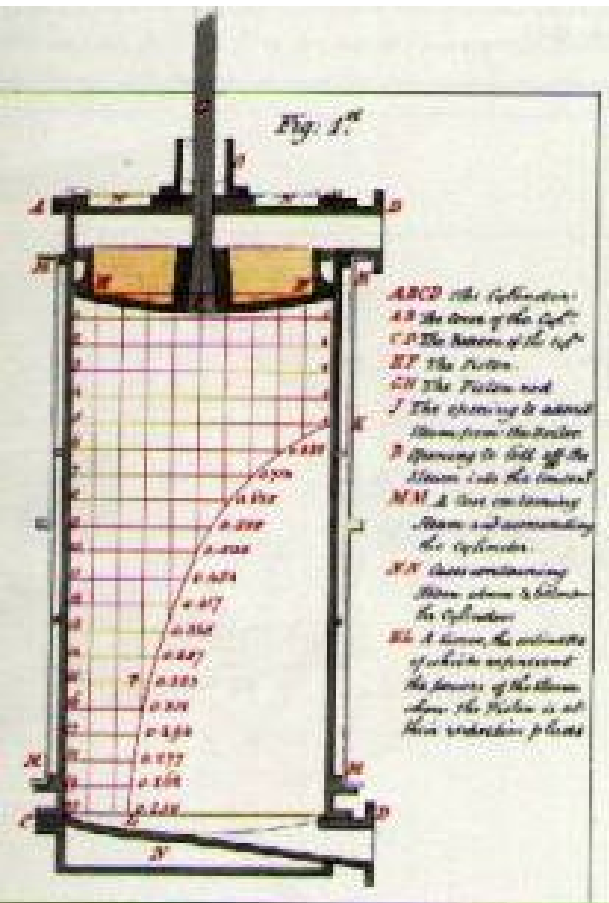

**Carnot** appreciated this ‘expansive principle’

*“Watt, who was responsible for nearly all the main improvements of the steam engine and who so perfected the engine that further advances would now be difficult, was also the first to use steam at progressively diminishing pressures.”*

*“The mark of a good steam engine, therefore, must be not only that it uses steam at a high pressure but also that it uses it at pressures which are not constant but which vary substantially from one moment to the next and progressively decrease.”*

**First,** a heat engine consists of three elements, a furnace, cooler, and working substance; the working substance can freely be separated from and forced to come in contact with the furnace and cooler.

**Second,** to perform work, not only a high temperature but also a low temperature is necessary. That is, heat is carried by the working substance from a high-temperature region (furnace) to a low-temperature region (cooler).

**Third,** work is performed by the volume change of the working substance. That is, the existence of a high temperature and a low temperature is a necessary but not sufficient condition for performing work; to perform work, the potential power of the high-temperature working substance should be extracted by expanding its volume.

# Carnot's premise—conservation of heat

- *“We think it unnecessary to explain here what is meant by the terms ‘amount of caloric (calorique)’ or ‘amount of heat (chaleur)’ (we use the two terms interchangeably) or to describe how to measure these quantities with a calorimeter. Nor shall we explain the meaning of latent heat, temperature, specific heat. etc. The reader should be familiar with these terms from elementary treatises on physics or chemistry.”*
- *“In our proof, we make the implicit assumption that when a body has undergone its various changes and after passing through a number of stages, has returned precisely to its original state (its state here being defined in terms of its density, temperature, and mode of aggregation), it contains the same quantity of heat as it did at the start.”*

$$\oint dq = 0$$



- *“If you were now to deprive England of her steam engines, you would deprive her of both coal and iron; you would cut off the sources of all her wealth, totally destroy her means of prosperity, and reduce this nation of huge power to insignificance.”*
- *First, “The question whether the motive power of heat is limited or whether it is boundless has been frequently discussed. Can we set a limit to the improvement of the heat engine, a limit which, by the very nature of things, cannot in any way be surpassed? Or, conversely, is it possible for the process of improvement to go on indefinitely?”*
- *Second, “is the motive power of heat fixed in quantity, or does it vary with the working substance that is used? Does it vary with the intermediary material that we subject to the action of heat?”*

# Motive power (work)

At that time, however, those who recognized the importance of motive power (work) and had grasped its concept clearly were **researchers of applied mechanics and engineers** rather than **those of mathematical physics.**

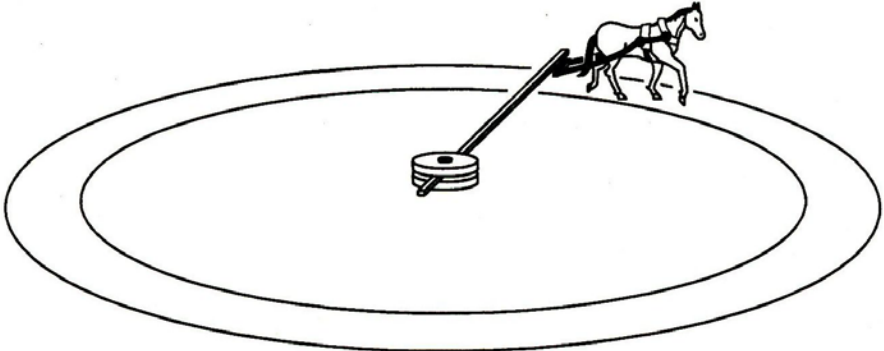

1 [hp]  
≡ 180[lb] × 2π × 12[ft] × 144/3600[s]  
= 550 [ft·lb/s] = 0.75 [kW]



Lazare Carnot



Hachette



Navier



Poncelet

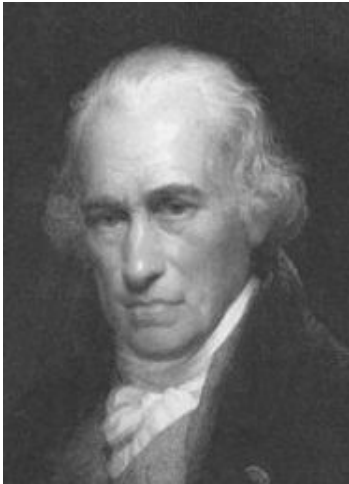

Watt

*“Wherever there is a difference in temperature, motive power can be produced.”*

This can be summarized to mean that a temperature difference is a necessary condition to produce motive power. The detailed description is as follows:

*“So the production of motive power in a steam engine is due not to an actual consumption of caloric but to its passage from a hot body to a cold one. It is due, in other words, to a restoration of the equilibrium of caloric after that equilibrium has somehow been disturbed, for example by a chemical reaction such as combustion, or by some other means.”*

The discovery that not only a high temperature but also a low temperature is necessary was Carnot's breakthrough.



# Carnot's preliminary theorem (2nd)

*“Obviously heat can only be a source of motion in so far as it causes substances to undergo changes in volume or shape.”*

**This can be summarized to mean that a change in the volume of substances is an indispensable condition for producing motive power.**

*“For there is nothing in nature that does not undergo changes in volume, contracting and then expanding as it experiences cold or heat; there is nothing which, in doing so, cannot act against a resisting force and there by develop motive power.”*

**This is precisely the theoretical specification of **Watt's expansive principle.****

*“Hence the necessary condition for the achievement of maximum effect is that the bodies used to produce motive power should undergo no change in temperature that is not due to a change in volume.”*

# Analogy with current of water (1)

*“From the ideas that have been established so far, we are sufficiently justified in comparing the motive power of heat with that of a fall of water. ..... The motive power of a fall of water depends on its height and on the amount of liquid. The motive power of heat likewise depends on the amount of caloric that is used and on what might be termed—in fact on what we shall call—the height of its fall; it depends, in other words, on the difference in temperature of the bodies between which the passage of caloric occurs”*

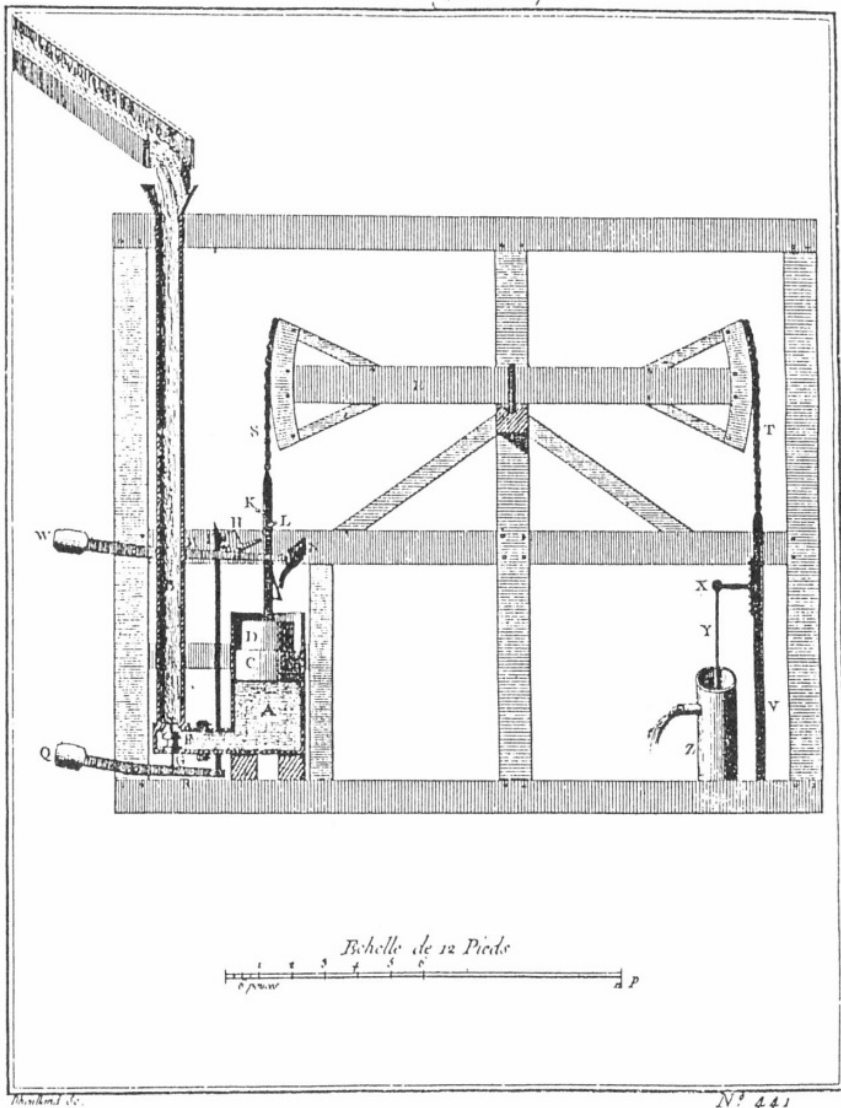

## Column-of-water engine

by modeling Newcomen's engine, a piston is operated by using **hydro pressure** instead of steam pressure

## Analogy with current of water (2)

**Lazare Carnot:** “**Essay upon Machines in General**” (1782)

*“We may conclude from this, for example, that the method of producing the greatest possible effect in a hydraulic machine moved by a current of water, is not to adapt a wheel to it, the wings of which receive the shock of the fluid. In fact, two good reasons prevent us from producing in this way the greatest effects:*

*the first is, as we have already said, because it is essential to avoid every kind of percussion whatever;*

*the second is, because after the shock of the fluid there is still a velocity which remains to it as a pure loss, since we should be able to employ this remainder in still producing a new effect to be added to the first.*

We can see the remarkable analogy between an ideal hydraulic machine which changes its state as slowly as possible and an ideal heat engine which operates through **a quasi-static process.**



# Not single process but cycle

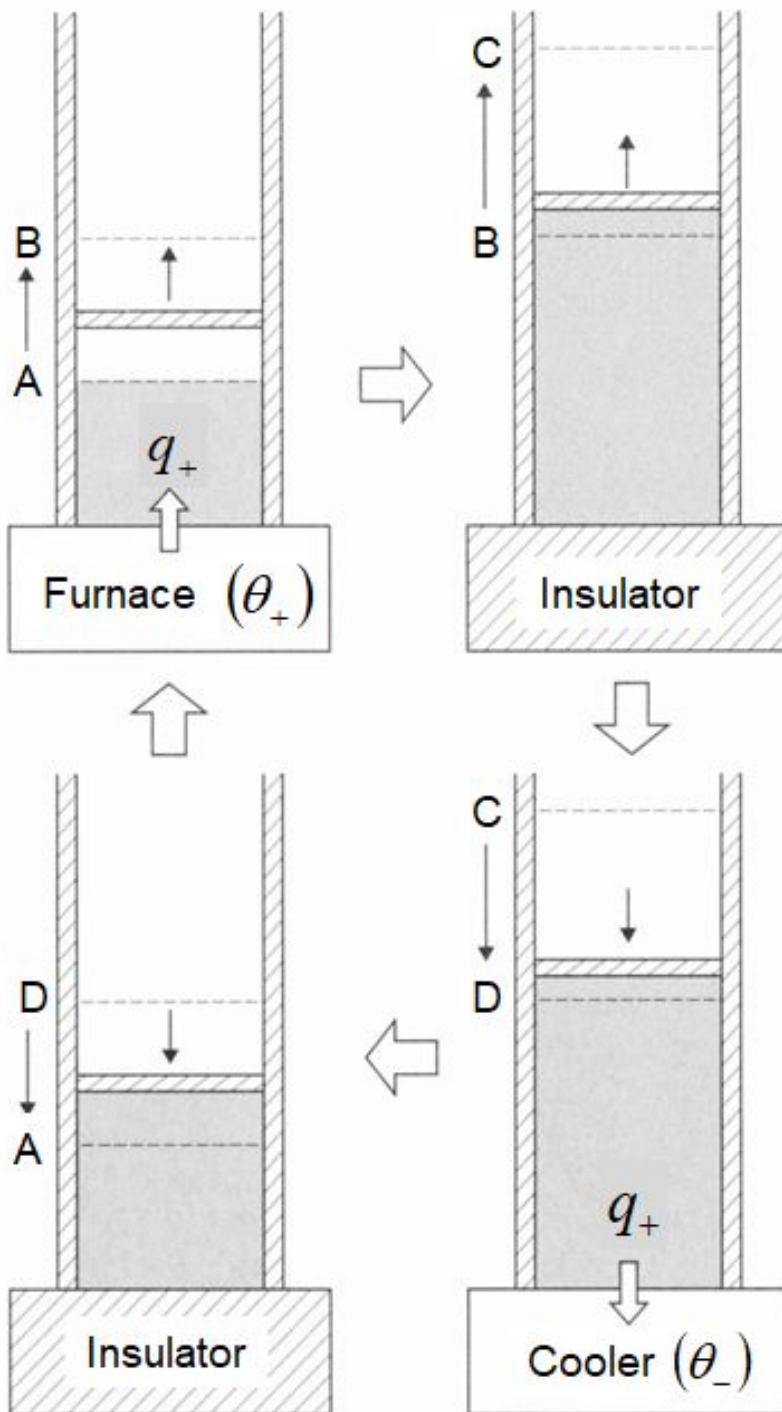

He was wise enough to consider not only a single process but also an entire cycle to clarify the work done by heat; at that time, all other scientists and engineers considered only the expansion process directly producing work.

The most important feature of the cycle

When the working substance has returned to the initial state, the heat added at the furnace—and the heat exhausted to the cooler in a Carnot cycle—is considered to be completely used for work to the outside. If the state has not returned to the initial state, however, part of the heat may be used to induce a physical internal change of the working substance, or conversely, the physical internal change of the working substance may be used to produce work.

On the basis of his preliminary theorem, the ideal engine must consist of isothermal and adiabatic processes.

# Carnot cycle starts from not A but $A_0$

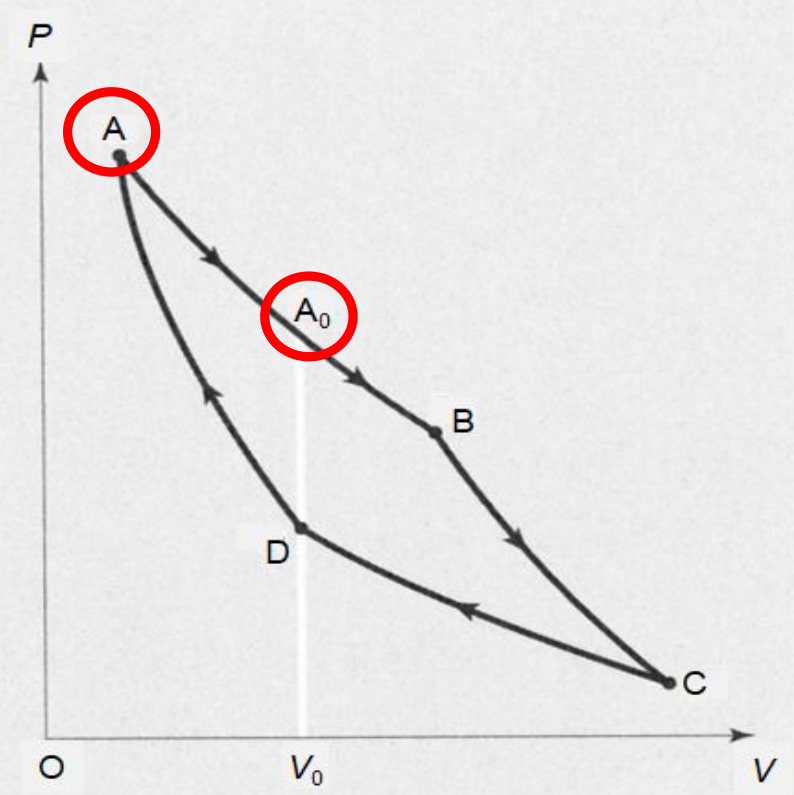

Explanation by **Clapeyron**:

- isothermal expansion:  $A \rightarrow B$
- adiabatic expansion:  $B \rightarrow C$
- isothermal compression:  $C \rightarrow D$
- adiabatic compression:  $D \rightarrow A$

- it might be considered that the existence of the heat function  $Q(\theta, V)$ , i.e., the conservation of heat, is necessary to close the cycle.
- however, this is not always the case.

Explanation by **Carnot**:

- isothermal expansion:  $A_0 \rightarrow B$
- adiabatic expansion:  $B \rightarrow C$
- isothermal compression:  $C \rightarrow D$
- adiabatic compression:  $D \rightarrow A$
- isothermal expansion:  $A \rightarrow A_0$

- Even if the sum of the heat absorbed during processes  $A \rightarrow A_0 \rightarrow B$  and the heat discharged to the cooler in process  $C \rightarrow D$  are different, this cycle is closed.
- This enabled the Carnot cycle to play a key role in the development of thermal science.

# Note: assumption and limited knowledge at the time (1824)

- Upon reading **Carnot**'s original paper after studying thermodynamics, it may be considered that his description of the above five processes is somewhat convoluted as well as strange; however, **we** should recognize that such a description was necessary.
- If **we** know the  $P$ - $V$  relationship for an adiabatic process—Poisson's formula  $PV^\gamma = \text{const.}$ , we can determine point D as the point which can adiabatically return to point A without using the relation (the sum of the heat absorbed during processes A→B and the heat discharged to the cooler in process C→D are equal), as employed by **Clapeyron**. Thus **Clausius** succeeded in removing the restriction of the conservation of heat.
- However, if we start from point D or B, the discussion is much simpler.

# Carnot's theorem

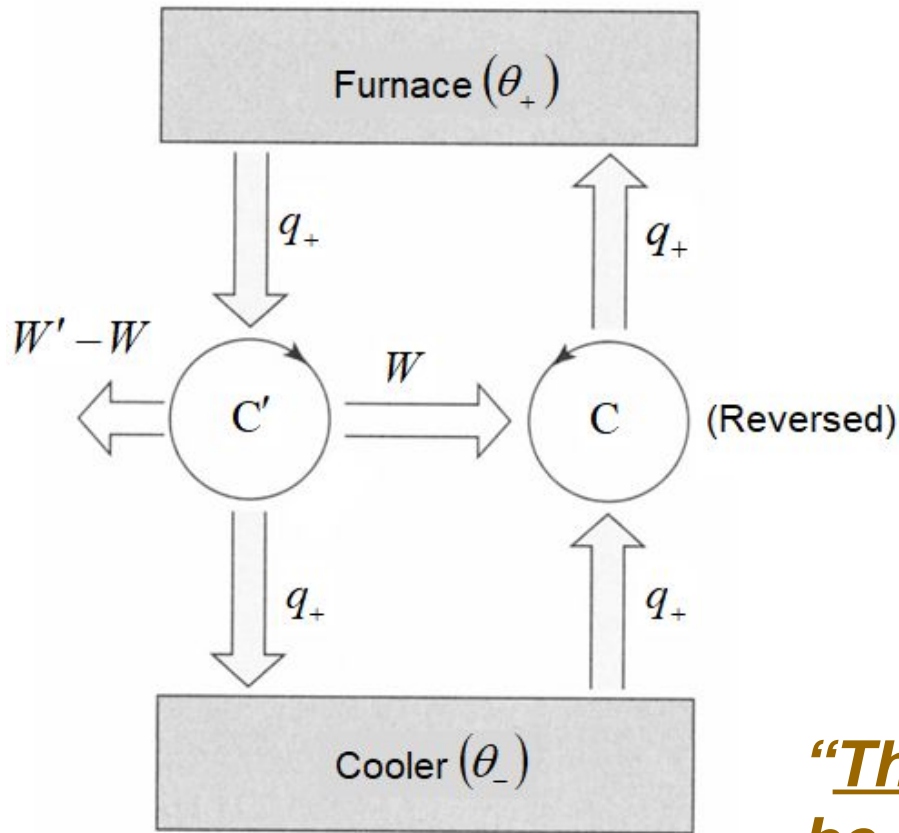

- *“Whether the motive power of heat is limited or whether it is boundless,”*
- *“is the motive power of heat fixed in quantity, or does it vary with the working substance that is used?”*

*“The whole sequence of operations just described can be reversed, and carried out in the opposite order.”*

By assuming that there is a cycle (referred to as C') between two temperatures and whose efficiency is superior to the Carnot cycle C,

*“We should then have a case not only of perpetual motion but of motive power being created in unlimited quantities without the consumption of caloric or of any other agent. Creation of this kind completely contradicts prevailing ideas, the laws of mechanics, and sound physics; it is inadmissible.”*



## 4. Structure of Carnot's Theory and its Extension

premises A, B, and C

Carnot's theorem  
(expressions I and II)

gas theorems 1, 2, and 3

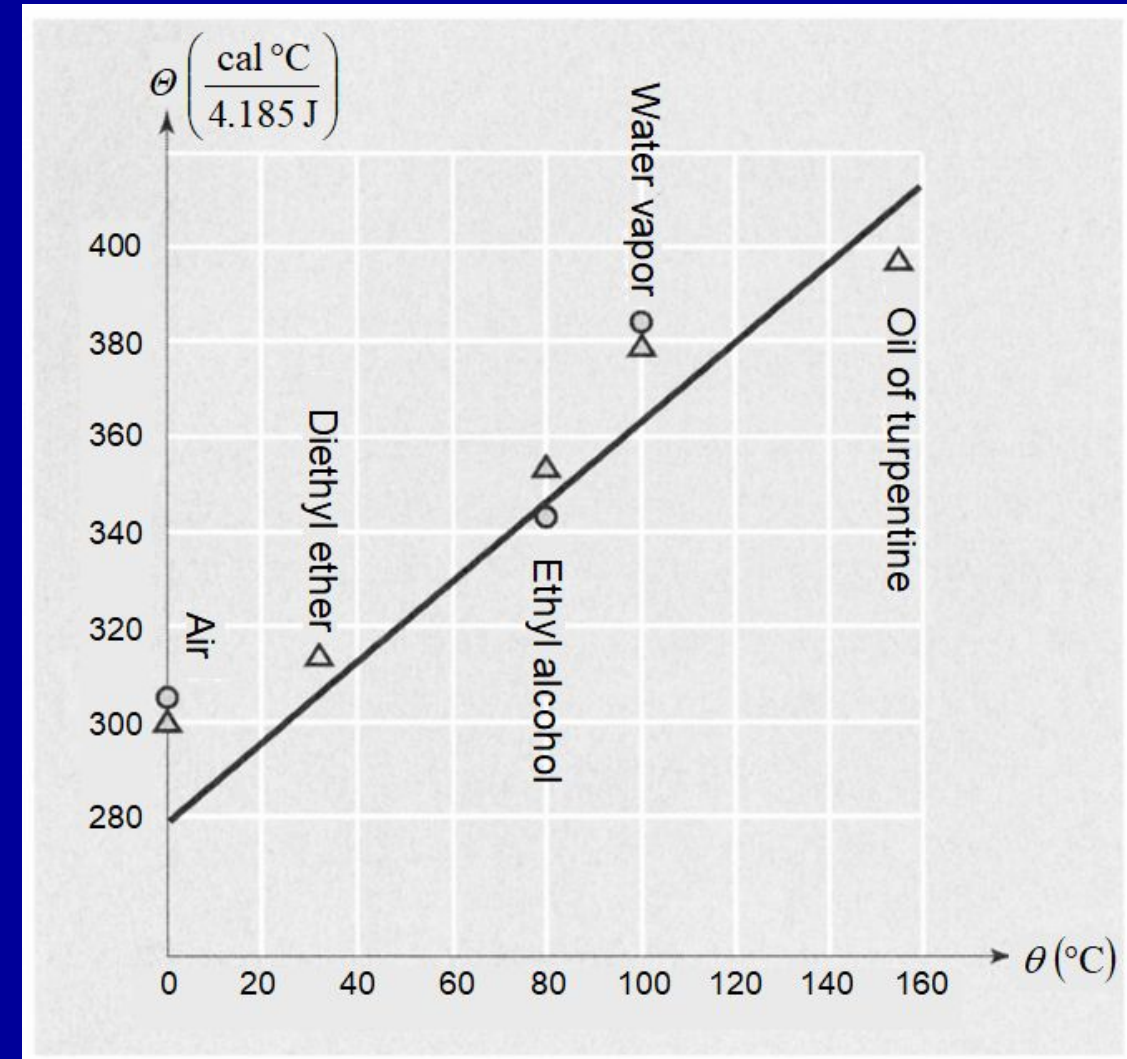

# Premises A, B, C

The basis of **Carnot's** heat theory is the same as that in the work of **Laplace** and **Poisson** except that the taking temperature  $q$  and volume  $V$  are considered as the variables; they are summarized by the following three premises:

**Premise A: paradigm of specific heat and latent heat**

$$dq = C_V d\theta + A_D dV \quad \text{where } A_D \text{ the latent heat of expansion.}$$

**Premise B: existence of the equation of state**

$$P = P(\theta, V) \quad \begin{array}{l} \text{for most ordinary gases,} \\ \text{the Boyle-Gay-Lussac law} \end{array} \quad P = R \frac{\alpha^{-1} + \theta}{V}$$

**Premise C: conservation of heat**

$$Q(\theta, V) = \int_{(\theta_0, V_0)}^{(\theta, V)} dq$$

- In most of the books about the history of thermal science, Premise A and Premise C are inseparably linked to each other.
- Although this is historically true, it is not logically true.
- **Premise A is not always associated with Premise C.**

# Analytical expression for Carnot's theorem

In general, the work for Carnot cycle is expressed as

$$W = W(q_+, \theta_+, \theta_-, V_A, V_B)$$

**Carnot's theorem: expression I**

$$\frac{W}{q_+} = \Psi(\theta_+, \theta_-)$$

$\Psi$  a universal function independent of the working substance

**Carnot's theorem: expression II.**

$$\lim_{\theta' \rightarrow \theta} \left\{ \frac{\Psi(\theta, \theta')}{\theta - \theta'} \right\} \equiv \frac{1}{\Theta(\theta)} \quad \text{where } \Theta(\theta) : \text{Carnot function}$$

$$\frac{\Delta W}{q_+} = \Psi(\theta, \theta - \Delta\theta) = \frac{\Delta\theta}{\Theta(\theta)}$$

The existence of this universal function is the key point of Carnot's theorem, and it is the ultimate basis of thermodynamics.

# Gas theorems

To confirm the correctness of a basic theory such as Carnot's theorem, however, a direct proof is not necessarily required. On the contrary, its extension, i.e., what is theoretically deduced from it, is more important.

## Gas theorem 1

*“When a gas passes from a particular volume and pressure to another specified volume and pressure, without undergoing a change in temperature, the amount of caloric absorbed or given out is always the same, whatever the gas on which the observation is made.”*

## Gas theorem 2

*“When the volume of a gas changes at a constant temperature, the amounts of heat absorbed or released by the gas will follow an arithmetical progression when the increases or decreases in volume follow a geometrical progression.”*

## Gas theorem 3

*“The difference between the specific heat at constant pressure and the specific heat at constant volume is the same for all gases.”*



# Most of Carnot's theory is correct

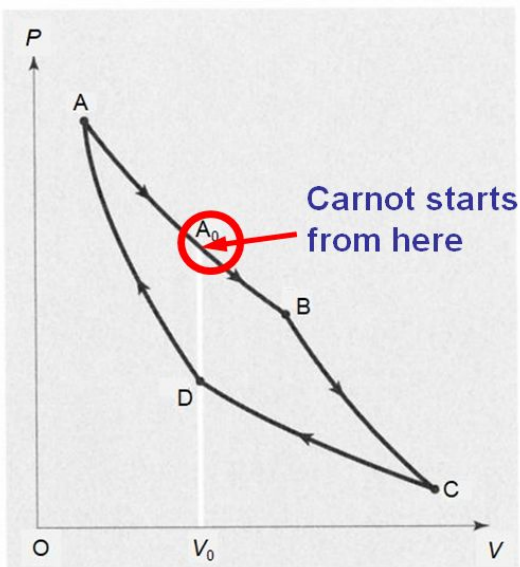

- Clapeyron proved the gas theorems firmly **on the basis of the existence of the heat function**. Consequently, **after the conservation of heat was later rejected**, these theorems were often regarded as having been obtained as a result of multiple errors cancelling each other out.

- However, **Premise A and Premise C are different; most of Carnot's theory was obtained from Premise A, and thus Premise C is not necessary.**
- Even if the conservation of heat does not hold, provided we consider an infinitesimally small cycle,

$$\oint dq = \text{infinitesimal quantity of the second order} \cong 0$$

**Thermodynamically correct results are often derived in practice.**

- Most of Carnot's mistakes are based on erroneously measured data relating to the pressure dependence of specific heat.

# Experimental determination of Carnot function

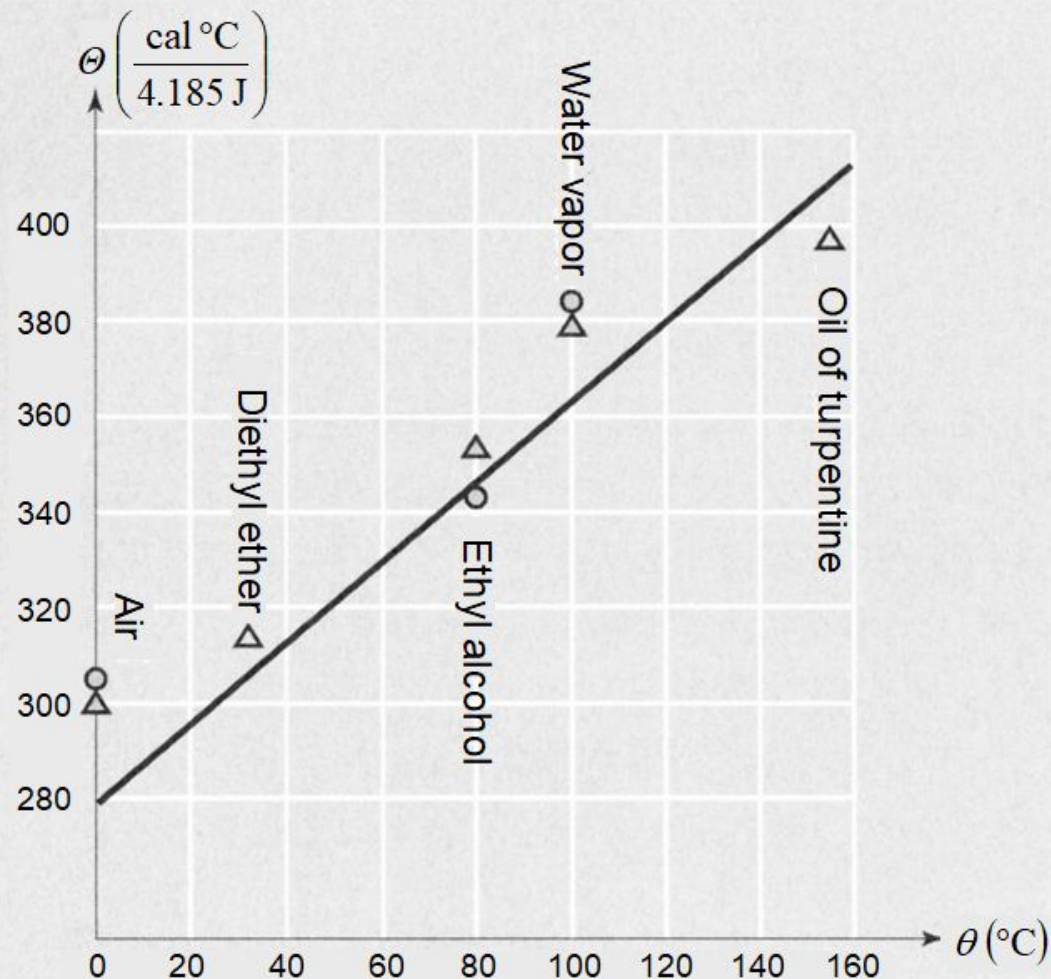

**Clapeyron** *“The function C (Carnot function) is, as we have seen, of great importance: it is the common link between the phenomena caused by heat in solid bodies, liquids and gases.”*

**Carnot** *“In order to test our basic proposition, to test whether the nature of the working substance that is used for developing motive power really has no bearing on the amount of power produced, we shall consider a number of substances in turn. These substances are air, steam, and alcohol vapour.”*

**Thomson** *“The complete theoretical investigation of the motive, power of heat is thus reduced to the experimental determination of the coefficient  $\mu$  ( $=1/\theta(\theta)$ ); and may be considered as perfect, when, by any series of experimental researches whatever, we can find a value of  $\mu$  for every temperature within practical limits.”*

## 5. Concluding remarks

(from **Preface** of the original book)

The creation of thermodynamics was a giant step toward understanding terrestrial phenomena. Looking back over the history of thermal science, from the very beginning, it developed with the aim of understanding the phenomena on earth, which is a unique environment for humanity and also a huge thermal engine.

Thermal science has retained its profound significance to this day, even though mainstream physics has shifted from macroscopic to microscopic subjects. The existence of humanity depends on the entropy balance of the globe.

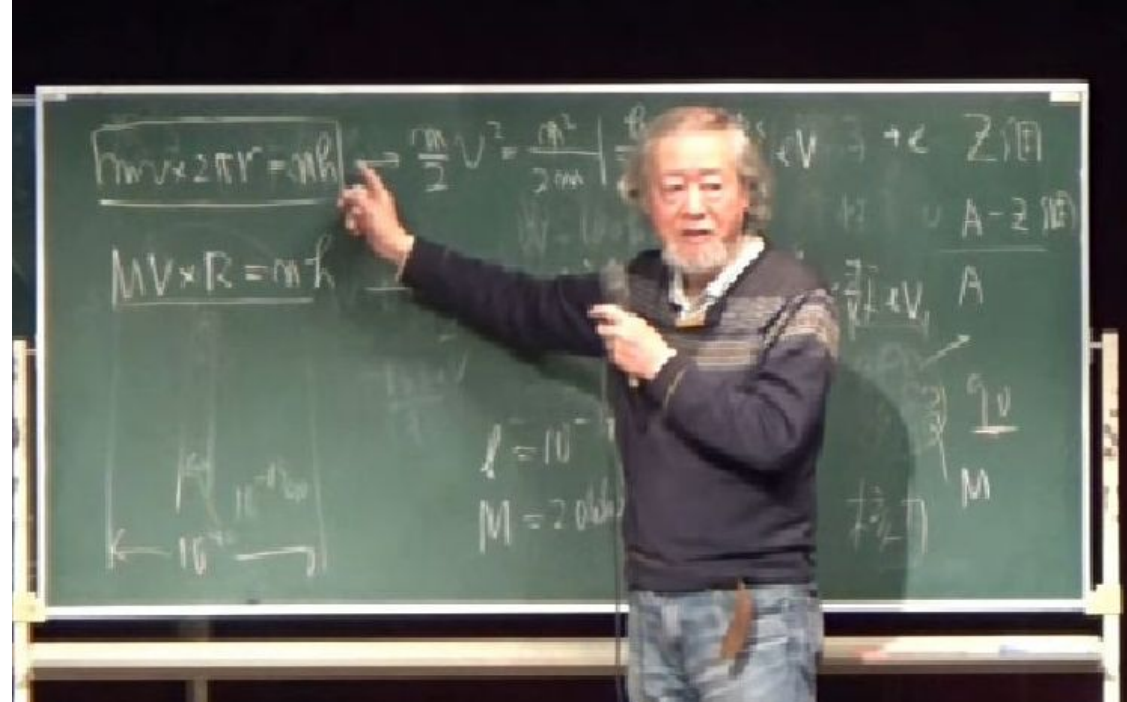

- Thank you very much for your kind attention.
- If you have any comments, please contact me by e-mail (sakura@hideoyoshida.com).
- I will be able to forward them to Mr. Yamamoto by post, because he does not use any internet.
- Two PDF files of this paper (54 pages) and this presentation will be shortly uploaded on <http://www.aihtc.org/history.html>